

## Models # 303119Z and 303119 (Current Sensing Fixed Foil Resistor Chips VCS1625Z/VCS1625 Configuration) Screen/Test Flow in Compliance with EEE-INST-002, (Tables 2A and 3A, Film/Foil, Level 1) and MIL-PRF-55342

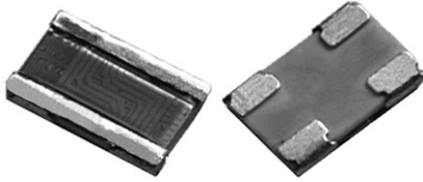

### INTRODUCTION

The Z-foil technology provides a significant reduction of the resistive component's sensitivity to ambient temperature variations (TCR) and applied power changes (PCR). Designers can now guarantee a high degree of stability and accuracy in fixed-resistor applications using solutions based on Vishay's revolutionary Z-foil technology. 0.05 ppm/°C absolute TCR removes errors due to temperature gradients.

Models 303119Z and 303119 are surface mount chip resistors designed with 4 pads for Kelvin connection. Utilizing Vishay's Bulk Metal® Z-foil as the resistance element, 303119Z provides performance capabilities far greater than other resistor technologies can supply in a product of comparable size.

These small devices dissipate heat almost entirely through the pads so surface mount users are encouraged to be generous with the board's pads and traces. Gold terminations are available as well.

Our application engineering department is available to advise and to make recommendations.

### FEATURES

- Temperature coefficient of resistance (TCR):  
± 0.05 ppm/°C typical (0 °C to + 60 °C)  
± 0.2 ppm/°C typical (- 55 °C to + 125 °C, + 25 °C ref.) (see table 1)
- Resistance range: 0.01 Ω to 10 Ω
- Vishay Foil resistors are not restricted to standard values, specific "as required" values can be supplied at no extra cost or delivery (e.g. 1.234 Ω vs. 1 Ω)
- Tolerance: to ± 0.5 %
- Power coefficient "ΔR due to self heating": 5 ppm at rated power
- Load life stability: 0.05 % at 70 °C, 2000 h at rated power
- Electrostatic discharge (ESD) up to 25 000 V
- Short time overload < 0.02 %
- Power rating: 0.5 W at + 70 °C (figure 1)
- Non inductive, non capacitive design
- Rise time: 1 ns effectively no ringing
- Current rating: 5 A maximum
- Current noise: < - 40 dB
- Voltage coefficient: < 0.1 ppm/V
- Non inductive: < 0.08 μH
- Non hot spot design
- For prototypes units, append a "U" to the model number (example: 303119ZU). These units have all of the table 2A (page 3) 100 % tests performed, with no destructive qualification testing required (table 3A, page 3). For more information, please contact [foil@vishaypg.com](mailto:foil@vishaypg.com)
- For oriented performances please contact us

**FIGURE 1 - POWER DERATING CURVE**

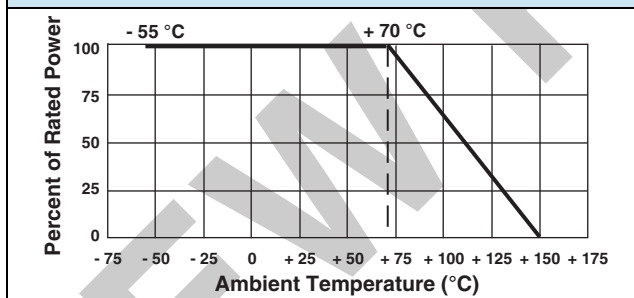

**TABLE 1 - SPECIFICATIONS**

MODEL NUMBER	RESISTANCE RANGE	TIGHTEST RESISTANCE TOLERANCE	TYPICAL TCR (- 55 °C to + 125 °C, + 25 °C ref.)	MAXIMUM TCR	POWER RATING at + 70 °C <sup>(1)</sup>	MAXIMUM CURRENT <sup>(1)</sup>
303119Z	> 2.0 Ω to 10 Ω > 0.5 Ω to 2.0 Ω 0.3 Ω to 0.5 Ω	± 0.5 % ± 1.0 % ± 2.0 %	± 0.2 ppm/°C	± 3 ppm/°C	0.5 W on FR4 PCB	5 A
303119	> 2.0 Ω to 10 Ω > 0.5 Ω to 2.0 Ω > 0.1 Ω to 0.5 Ω > 0.05 Ω to 0.1 Ω > 0.03 Ω to 0.05 Ω > 0.01 Ω to 0.03 Ω	± 0.5 % ± 1.0 % ± 2.0 % ± 2.0 % ± 2.0 % ± 2.0 %	± 2.0 ppm/°C	± 5 ppm/°C ± 10 ppm/°C ± 15 ppm/°C ± 20 ppm/°C ± 30 ppm/°C ± 50 ppm/°C		

**Note**

<sup>(1)</sup> Whichever is lower

**FIGURE 2 - DIMENSIONS** in Inches (Millimeters)

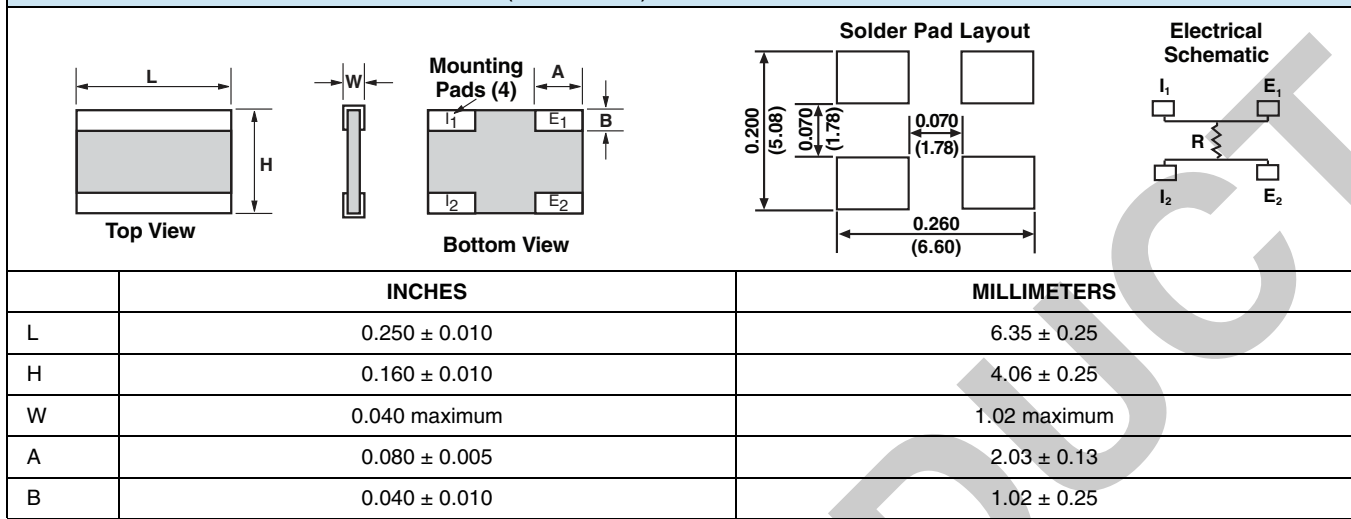

**FIGURE 3 - TRIMMING TO VALUES**  
(Conceptual Illustration)

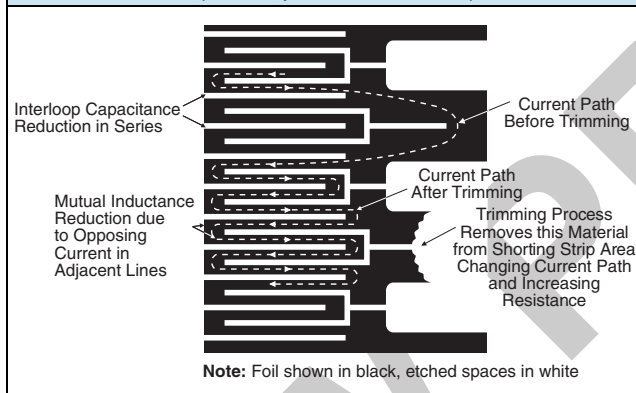

**FIGURE 4 - TYPICAL TCR CURVE Z-FOIL**

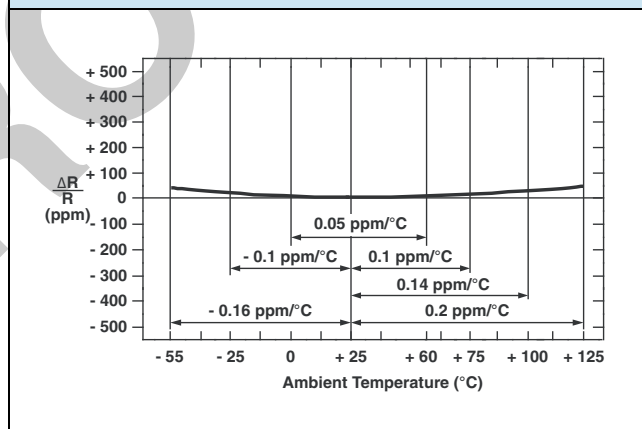

**TABLE 2 - PERFORMANCE SPECIFICATIONS**

TEST	MIL-PRF-55342 ΔR LIMITS	TYPICAL ΔR LIMITS	MAXIMUM ΔR LIMITS (1)
Thermal shock 5 x (- 65 °C to + 150 °C)	± 0.10 %	± 0.005 % (50 ppm)	± 0.01 % (100 ppm)
Low temperature operation	± 0.10 %	± 0.005 % (50 ppm)	± 0.02 % (200 ppm)
Short time overload	± 0.10 %	± 0.005 % (50 ppm)	± 0.02 % (200 ppm)
High temperature exposure	± 0.10 %	± 0.01 % (100 ppm)	± 0.1 % (1000 ppm)
Resistance to soldering heat	± 0.2 %	± 0.01 % (100 ppm)	± 0.03 % (300 ppm)
Moisture resistance	± 0.2 %	± 0.01 % (100 ppm)	± 0.03 % (300 ppm)
Load life 2000 h at 70 °C: rated power on FR4 PCB	± 0.5 %	± 0.02 % (200 ppm)	± 0.05 % (500 ppm) for values ≥ 100 mΩ ± 0.1 % (1000 ppm) for values < 100 mΩ

**Note**

(1) Measurement error 0.001R

**NOTES**

- Tightest absolute tolerance:  
 ≥ 10 mΩ to 500 mΩ inclusive, 2 %  
 > 500 mΩ to 2 Ω inclusive, 1 %  
 > 2 Ω to 10 Ω inclusive, 0.5 %
- Measurement error allowed for ΔR limits: 0.001 Ω (if not otherwise specified)
- For prototypes units, append a “U” to the model number (example: 303119ZU). These units have all of the table 2A 100 % tests performed, with no destructive qualification testing required

<b>TABLE 3 - EEE-INST-002 (TABLE 2A FILM/FOIL, LEVEL 1) 100 % TESTS/INSPECTIONS (1)</b>	
RC Record	In tolerance
Thermal Shock	25 x (- 65 °C to + 150 °C)
Power Conditioning	70 °C, 100 h, rated power - not to exceed max. current
RC Record	In tolerance, ΔR = 0.05 % for thermal shock and conditioning combined
Final Inspection	5 % PDA on ΔR only 10 % PDA on “Out of Final Tolerance” Measurement error allowed on ΔR limits: 10 mΩ to 100 mΩ: 0.0001 Ω ≥ 100 mΩ to 1 Ω: 0.0005 Ω ≥ 1 Ω to 10 Ω: 0.005 Ω or 0.1 %, whichever is smaller
Visual Inspection	Materials, design, etc.
Mechanical Inspection	Physical dimensions sample size: 3 units for a min. of one failure - 100 % inspection

**Note**

(1) Vishay will perform a pre-cap visual inspection 100 % in the production flow prior to overcoating

<b>TABLE 4 - EEE-INST-002 (TABLE 3A FILM/FOIL, LEVEL 1) DESTRUCTIVE TESTS</b>																							
<b>Group 2</b>	Solderability Sample size: 3(0)																						
<b>Group 3</b>	Sample size: 10(0) - mounted on FR4																						
	TCR Temperature range: - 55 °C/+ 25 °C/+ 125 °C																						
	<table border="1"> <thead> <tr> <th colspan="2">303119Z Series</th> </tr> <tr> <th>Values</th> <th>TCR limits</th> </tr> </thead> <tbody> <tr> <td>0.3 Ω to 10 Ω</td> <td>± 3 ppm/°C</td> </tr> <tr> <th colspan="2">303119 Series</th> </tr> <tr> <th>Values</th> <th>TCR limits</th> </tr> <tr> <td>&gt; 2 Ω to 10 Ω</td> <td>± 5 ppm/°C</td> </tr> <tr> <td>&gt; 0.5 Ω to 2 Ω</td> <td>± 10 ppm/°C</td> </tr> <tr> <td>&gt; 0.1 Ω to 0.5 Ω</td> <td>± 15 ppm/°C</td> </tr> <tr> <td>&gt; 0.05 Ω to 0.1 Ω</td> <td>± 20 ppm/°C</td> </tr> <tr> <td>&gt; 0.03 Ω to 0.05 Ω</td> <td>± 30 ppm/°C</td> </tr> <tr> <td>&gt; 0.01 Ω to 0.03 Ω</td> <td>± 50 ppm/°C</td> </tr> </tbody> </table>	303119Z Series		Values	TCR limits	0.3 Ω to 10 Ω	± 3 ppm/°C	303119 Series		Values	TCR limits	> 2 Ω to 10 Ω	± 5 ppm/°C	> 0.5 Ω to 2 Ω	± 10 ppm/°C	> 0.1 Ω to 0.5 Ω	± 15 ppm/°C	> 0.05 Ω to 0.1 Ω	± 20 ppm/°C	> 0.03 Ω to 0.05 Ω	± 30 ppm/°C	> 0.01 Ω to 0.03 Ω	± 50 ppm/°C
	303119Z Series																						
Values	TCR limits																						
0.3 Ω to 10 Ω	± 3 ppm/°C																						
303119 Series																							
Values	TCR limits																						
> 2 Ω to 10 Ω	± 5 ppm/°C																						
> 0.5 Ω to 2 Ω	± 10 ppm/°C																						
> 0.1 Ω to 0.5 Ω	± 15 ppm/°C																						
> 0.05 Ω to 0.1 Ω	± 20 ppm/°C																						
> 0.03 Ω to 0.05 Ω	± 30 ppm/°C																						
> 0.01 Ω to 0.03 Ω	± 50 ppm/°C																						
Low temperature storage	ΔR = 0.02 % - 65 °C no load dwell for 24 h ± 4 h + 25 °C ambient no load dwell for 2 h to 8 h																						
Low temperature operation	ΔR = 0.02 % - 65 °C no load dwell for 1 h rated power for 45 min + 25 °C ambient no load dwell for 24 h ± 4 h																						
Short time overload	ΔR = 0.02 % 6.25 x rated power, 5 s - no “I” limitation: not to exceed twice the max. voltage																						
<b>Group 4</b>	Sample size: 9(0) - mounted on FR4																						
Resistance to Soldering Heat	ΔR = 0.03 % performed per MIL-PRF-55342 para. 4.8.8.1																						

**TABLE 4 - EEE-INST-002 (TABLE 3A FILM/FOIL, LEVEL 1) DESTRUCTIVE TESTS**

<b>Group 6</b>	Sample size: 12(0) - mounted on FR4	
	Life	2000 h, + 70 °C, rated power ΔR = 0.05 % for values ≥ 100 mΩ ΔR = 0.1 % for values < 100 mΩ performed per MIL-PRF-55342
<b>Group 7B</b>	Sample size: 10(0) - mounted on FR4	
	Solder Mounting Integrity	Performed per MIL-PRF-55342 3 kg force, 30 s
<b>Group 9</b>	Sample size: 5(0) - mounted on FR4	
	High temperature exposure	ΔR = 0.1 % Performed per MIL-PRF-55342 100 h at + 150 °C ± 5 °C

**Note**

- The sample units should be randomly selected from lots which successfully passed the table 2A tests

**PART NUMBER IDENTIFICATION**

<b>Model #</b>	303119Z	303119
<b>Base Model</b>	VCS1625Z	VCS1625
<b>Value Range</b>	0.3 Ω to 10 Ω	0.01 Ω to 10 Ω

Part Number:

{Model} - {Value} - {Tolerance} - {Termination} - {Packaging}

303119Z		
Resistance Value	Max. Tolerance	Code
0.3 Ω to 0.5 Ω	2 %	G
> 0.5 Ω to 2 Ω	1 %	F
> 2 Ω to 10 Ω	0.5 %	D

Termination	Code
Tin/lead	B

Packaging	Code
Waffle	W
Tape and reel	T

303119		
Resistance Value	Max. Tolerance	Code
0.01 Ω to 0.5 Ω	2 %	G
> 0.5 Ω to 2 Ω	1 %	F
> 2 Ω to 10 Ω	0.5 %	D

**Example:** 303119Z - 2R3 - FBW

VCS1625Z, 2.3 Ω, 1 %, tin/lead termination, waffle packaging

## Disclaimer

All product specifications and data are subject to change without notice.

Vishay Precision Group, Inc., its affiliates, agents, and employees, and all persons acting on its or their behalf (collectively, "Vishay Precision Group"), disclaim any and all liability for any errors, inaccuracies or incompleteness contained herein or in any other disclosure relating to any product.

Vishay Precision Group disclaims any and all liability arising out of the use or application of any product described herein or of any information provided herein to the maximum extent permitted by law. The product specifications do not expand or otherwise modify Vishay Precision Group's terms and conditions of purchase, including but not limited to the warranty expressed therein, which apply to these products.

No license, express or implied, by estoppel or otherwise, to any intellectual property rights is granted by this document or by any conduct of Vishay Precision Group.

The products shown herein are not designed for use in medical, life-saving, or life-sustaining applications unless otherwise expressly indicated. Customers using or selling Vishay Precision Group products not expressly indicated for use in such applications do so entirely at their own risk and agree to fully indemnify Vishay Precision Group for any damages arising or resulting from such use or sale. Please contact authorized Vishay Precision Group personnel to obtain written terms and conditions regarding products designed for such applications.

Product names and markings noted herein may be trademarks of their respective owners.